

Specifications

Output Power HP (kW)	5 (3.7)
Phase	3 Phase
Pole	2 Pole
Frame Number	112M

Degrees of Protection	IP 55
Enclosure Construction	Totally-enclosed Fan-cooled
Thermal Class	Class F (155 °C)

Alignment	Vertical
Frame Material	Steel plate

Power Transmission	Direct-couple or Belt Driven
Direction of Rotation	Counterclockwise (CCW) viewed from shaft-end side

Connection Type	Terminal Block (6 Leads)
Coating Colour	Munsell N5.5 (Gray)
Conformed Standard	IEC 60034-1 & JEC-2137-2000

Voltage & Frequency	LT Type
	220/380-415V 50Hz 220/440V 60Hz

Motor Characteristics

Type	Hz	V	50% Load			75% Load			100% Load				Torque(%)		Is (A)	Inertia GD <sup>2</sup> (kg-m <sup>2</sup> )	
			(A)	Eff(%)	PF(%)	(A)	Eff(%)	PF(%)	(A)	Eff(%)	PF(%)	Speed (r/min)	Torque (kg-m)	Ts			Tm
LT	50	220	7.13	0.86	0.79	9.56	0.88	0.87	12.3	0.88	0.90	2890	1.25	213	287	90.8	0.029
		380	4.13	0.86	0.79	5.53	0.88	0.87	7.12	0.88	0.90	2890	1.25	213	287	52.4	
		415	4.36	0.84	0.70	5.50	0.88	0.80	6.84	0.88	0.86	2910	1.24	256	342	57.3	
	60	220	6.63	0.86	0.85	9.25	0.87	0.90	12.2	0.87	0.92	3470	1.04	166	249	77.0	
		440	3.74	0.84	0.77	4.90	0.86	0.86	6.21	0.88	0.89	3490	1.03	224	335	51.4	

Dimensions (mm)

Flange Number	Motor								
	D	IE	LA	LB	LC	LE	LG	LL	LZ
FF215	230	141	215	180 j6	250	4	16	351	14.5

Terminal Box			Shaft End						
KD	KG	KL	LR	Q	QK	S	T	U	W
PF 3/4	174	180	60	60	45	28 j6	7	4	8

Bearing No.		Approximated Weight (kg)	Approximated Packing Dimensions (LxWxH)	Gross Weight (kg)
Drive End	Opposite			
6207ZZ	6206ZZ	37	507 x 401 x 357	44

Connection & Connection Diagram

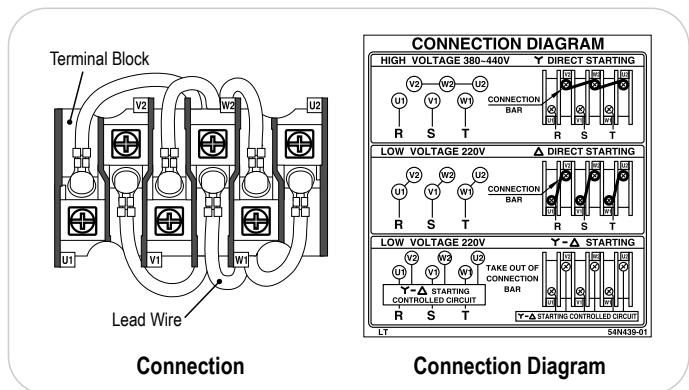

Circumstance Conditions

Ambient Temperature	-20 ~ +40°C
Ambient Humidity	95% RH or less
Operating Altitude	Less than 1,000m above sea level
Environment	No bursting / erosive gas or vapor